

VMM-19 Series

Rugged 19 inch Monitor

- 19" Industrial-Grade LCD Monitor
- 4:3 / 5:4 Aspect Ratio
- 350 nits Brightness
- TRU-Tuff Treatment Ensures Maximum Shock & Vibration Resistance
- Auto Re-Start After Power Loss
- Lockable On-Screen Display Controls
- Can Be Customized to Meet Your Needs
- 3-Year Warranty



19 INCH MONITOR WITH 5:4 / 4:3 ASPECT RATIO

The VMM-19 Series are industrial 19 inch monitors. They offer 1280 x 1024 resolution and a 5:4 aspect ratio. Additionally, the panels offer up to 350 nits brightness. They are ideal for use with analog cameras, and BNC cameras. Likewise, many legacy machine vision systems benefit. Furthermore, we build them with true industrial-grade components for long-term reliability. For example, they receive our exclusive TRU-Tuff treatment. Moreover, the TRU-Tuff process includes RTV silicone on all connections and critical components. Additionally, all wires are dressed, tie-wrapped and secured. Lastly, we apply ThreadLock to all screws to ensure they remain secured. This results in a rugged, dependable monitor you can rely on. They can operate on 12-24VDC or 12 VDC.

RUGGED 19" DISPLAYS BUILT FOR DEMANDING APPLICATIONS

The VMM-19 Series also provide a brighter-than-normal, with 350 nits brightness. The result is crisp, vibrant video images. TRU-Vu industrial LCD monitors are specifically designed for use in demanding industrial, commercial, and A/V applications. For instance, every TRU-Vu monitor utilizes industrial-grade components and high-end LCD panels not found in retail or consumer-grade monitors. This ensures superior image quality, improved performance and greater durability.

The VMM-19 Series industrial 19" LCD monitors offer a variety of video inputs and are available in standard, open frame, rack mount, panel mount, NEMA/IP waterproof, and touch screen configurations. An extensive list of available OEM options enables you to customize a solution to your specific needs.

19 INCH MONITORS DEPLOYED WORLDWIDE

The VMM-19 Series 19 inch monitor 5:4 aspect ratio are deployed in many industries and applications. This includes manufacturing plants, machine vision inspection systems, and food and beverage plants. They are also found in surveillance systems, specialty vehicles, museums and pipeline inspection systems.

TRU-Vu monitors are backed by our full 3-year warranty. Consequently, this ensures you of many years of reliable service.

OUR TECHNICAL EXPERTS ARE READY TO HELP YOU FIND THE BEST 19" LCD MONITOR

With over 540 LCD monitors and touch screens on our site, selecting the ideal equipment, or touch screen solution may be a bit overwhelming. To help narrow down the choices, check out our [Advanced Search Tool](#). For example, this enables you filter by your own specific search requirements. See our full line of [standard brightness monitors](#) and [13.3" to 19" monitors](#)

for similar models to the VMM-19 Series. Browse all monitors and touch screens on sale. They can also be private-labeled with your company name and/or logo on the front bezel.

Finally, our team members are ready to help! We can determine the exact solution that will meet your specific needs . Certainly, TRU-Vu will help provide clear images for your operating requirements . Call (847) 259-2344 today to speak with one of our specialists. Above all, we will listen. It’s one of the things we do best. Our professional advisors will ensure the monitor or touch screen you receive will be and do everything you had hoped it would!

If you prefer, fill out a quick form with your requirements, and we will guide you to the proper models that will work best.

To see technical information, tips, tricks and guides to LCD monitors and technology, visit our [TECH CENTER](#).

SPECIFICATIONS

	VMM-19U	VMM-19U-24	VMM-19C-24
LCD Panel	19" Color Defect-Free LCD; LED Backlights		
Display Resolution	1280 x 1024 (SXGA)		
Viewable Area	14.81" (W) x 11.85" (H) (376.17 x 300.98 mm)		
Pixel Pitch	0.294mm x 0.294mm		
Display Colors	16.7 Million		
Aspect Ratio	4:3 (5:4)		
Brightness	250 nits	350 nits	250 nits
Contrast Ratio	1000:1		
Viewing Angle	170° (H) x 160° (V)		
Response Time	5 msec Trf		
Control	OSD (On-Screen Display) via Front Panel Pushbuttons		
Video Inputs	VGA, HDMI, BNC Loop-Thru NTSC/ PAL Auto- Recognition		VGA, DVI-D
In/Output Impedance	75Ω / Auto Terminating Output		---
Audio	Rear Speakers	Optional	Front Speakers
Power Requirement	12 VDC (2.1 mm Barrel Plug); 90-240 VAC via Included Power Brick	12-24 VDC	12-24 VDC
Power Consumption	18 Watts		
Enclosure	ABS		
Mounting	75 x 75mm Rear VESA Mount Holes	Via Included Mounting Stand or Rear 75 x 75mm Rear VESA Mount Holes	
Operating Temperature	32° to 140° F (0° to 60° C)		
Operating Altitude	To 18,000 Ft.		
Humidity	5-90% RH		
Shock	50 G (20 msec, 1/2 sine)		
Vibration	1.5G RMS 10-200 HZ		
Approvals	UL/cUL, FCC, CE, RoHS	RoHS	RoHS
Dimensions	16.59" (W) x 13.79" (H) x 1.85" (D) (421.40 x 350.50 x 47.1 mm)		
Weight	8 lbs. (3.62 kg)		
Warranty	3-Years		

Note: Specifications subject to change without notice.

DIMENSIONS (MM)

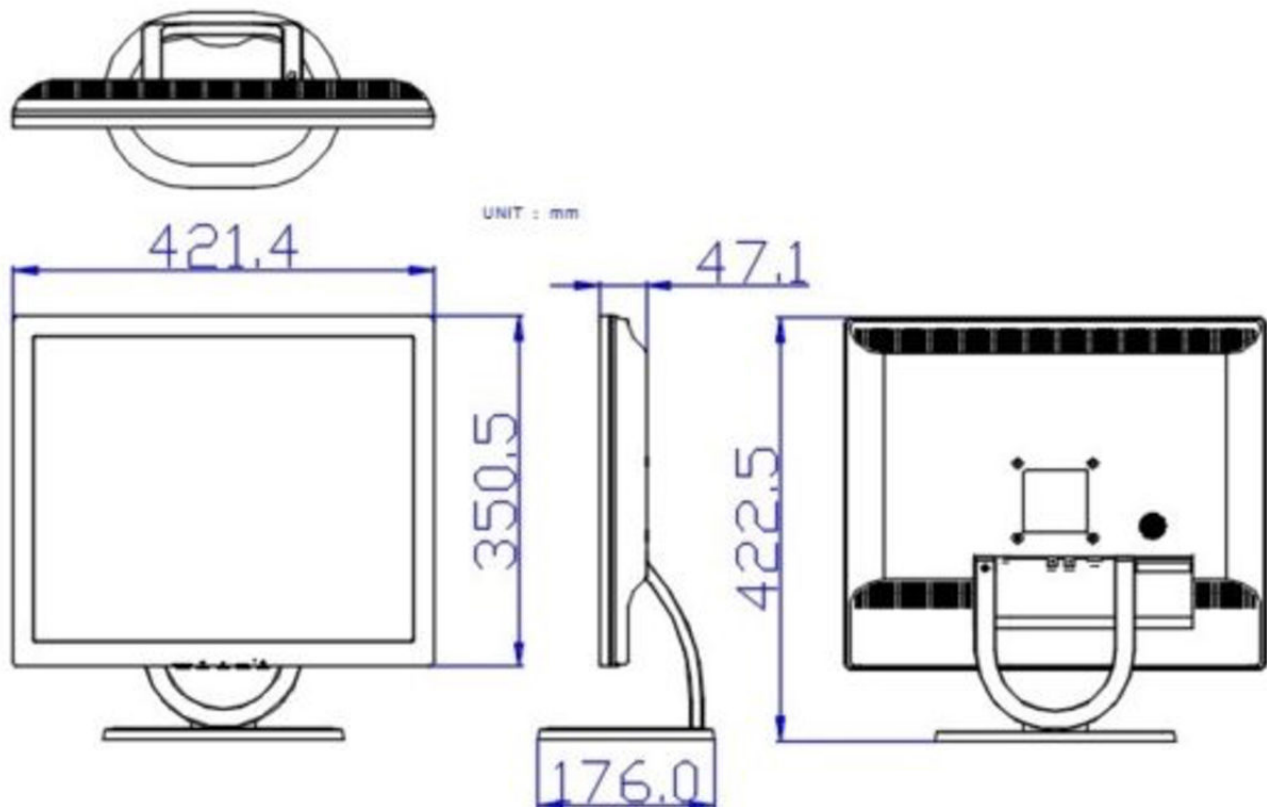

Standard Accessories:

- 90-240 VAC Power Brick (VMM-19U)
- Tabletop Stand (Except VMM-19U)
- VGA Cable
- Audio Cable (Except VMM-19U-24)
- DVI Cable (VMM-19C-24 Only)
- Power Pigtail (VMM-19U-24 and VMM-19C-24 Only)

Available Options:

- -22°F to +185°F Operating Temperature
- 100-240VAC Power Adaptor (PS-12)
- S-Video Input (VMM-19S)
- 1,000 Nits Brightness (SRM-19B-24)
- Optical Bonding (VMMOB-19 Series)
- Panel Mount Enclosure
- Anti-Reflective or Vandal-Resistant Glass
- Steel Enclosure
- NEMA 4X Waterproof Stainless Steel Enclosure
- Touch Screen (VMTC-19C)
- Rack Mount Bracket MB-Rack-19
- Open-Frame Configuration
- Private-Label

- 9-36 VDC Power